

HW-18 ELECTRIC VEHICLE AC CHARGER PRODUCT MANUAL

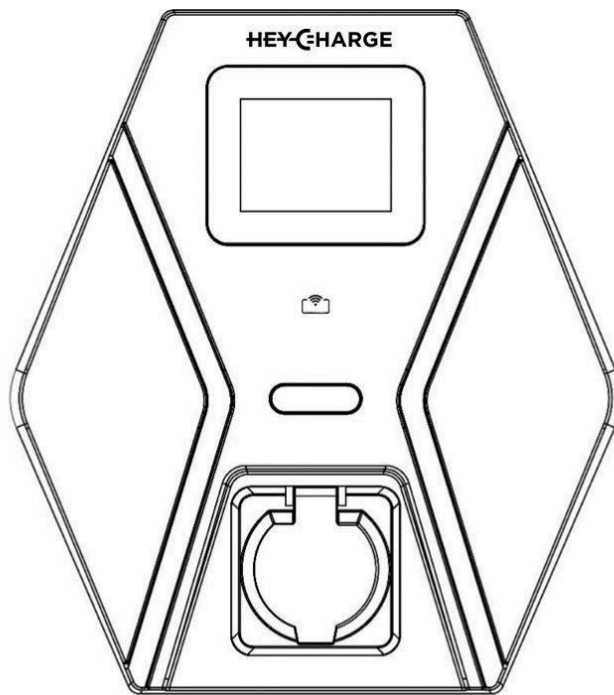



WARNING

1. Safety and standards

This charger complies with IEC-61851 and CE-LVD.

When using electric products, basic precautions should always be followed. This manual contains important instructions, including the following, that must be followed during installation, operation and maintenance.

- Do not install or use the charger near flammable, explosive, corrosive, or combustible materials, chemicals, or vapors.
- Turn off the input power of the charger before maintaining the charger.
- The device is designed only for vehicles that are compatible with the Model 3 charging standard.
- Do not use the charger if it is defective, appears cracked, frayed, broken or damaged.
- Do not attempt to open, disassemble, repair, tamper with, or modify the charger. Contact our Customer Service for any requirement of repair.
- Do not use the charger when you are in the vehicle, or the charger is exposed to severe rain, snow, or other severe weather.
- When transporting the charger, handle it with care and do not drag or step on the device.
- Do not touch the charging connector terminal with sharp metallic objects to prevent damage.
- Do not forcefully pull the charging cable, damage it with sharp objects, put fingers, or insert foreign objects into any part of the charging connector.
- Risk of explosion. This device has arcing or sparking parts that should not be exposed to flammable vapors.
- Risk of electric shock. Do not remove the cover or attempt to open the enclosure of the device. No user-serviceable parts inside. Refer servicing to qualified service personnel.
- To reduce the risk of serious injury or death and damage to the charge, this device should be installed, adjusted, and serviced by qualified electrical personnel familiar with the construction and operation of this type of charger and the danger involved. Failure to observe this precaution could result in death or severe injury.
- Incorrect installation and testing of the charger could potentially damage

either the vehicle's battery and/or the device itself. Any resulting damage is excluded from the warranty for the device.

- Ensure that the charging cable is well positioned during charging so it will not be stepped on, tripped over, or subjected to damage or stress.
- Do not use this charger with a frayed charging cable that has damaged insulation or any other sign of damage.
- According to the local electrical requirements, confirm the wire diameter and wire type corresponding to the current rating and the temperature rating must meet the requirements.
- Before starting the installation, turn off all power.
- Read additional environmental requirements in the “Maintenance and Warranty” chapter at the end.

For safe use of electricity, please add circuit breaker protection in the input part of the charging pile, and install certified type A RCD and circuit breaker (Schneider) upstream close to the AC charger.

table: Circuit breaker options

<u>Characteristic</u>	<u>Single phase</u>	<u>Three phase</u>	
Your powerline capacity	32A	16A	32A
Required circuit breaker	≥40A	≥20A	≥40A

2. Packing list

Check the box to ensure you have the parts listed below:

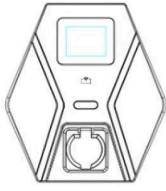

1

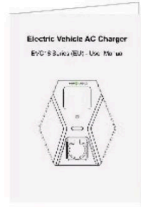

2

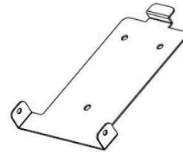

3

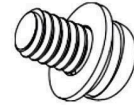

4

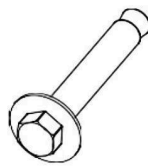

5

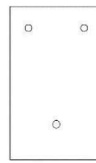

6

table: Packing list

#	Name	Qty	Description
1	AC charger	1	With attached input power cable.
2	Product Manual	1	
3	Wall-mounted bracket	1	For mounting the charger to the wall or pedestal.
4	M5 round head screws	2	For securing the charger to the Mounting Bracket
5	M6 hexagonal expansion screws	3	For installing the Mounting Bracket to the wall or pedestal
6	Mounting template	1	For easy drilling of 3 screw holes for wall-mounted bracket.

Note: Please contact seller if you are missing any of the parts in the list.

3. Nameplate

You can find the nameplate on the left side of the device.

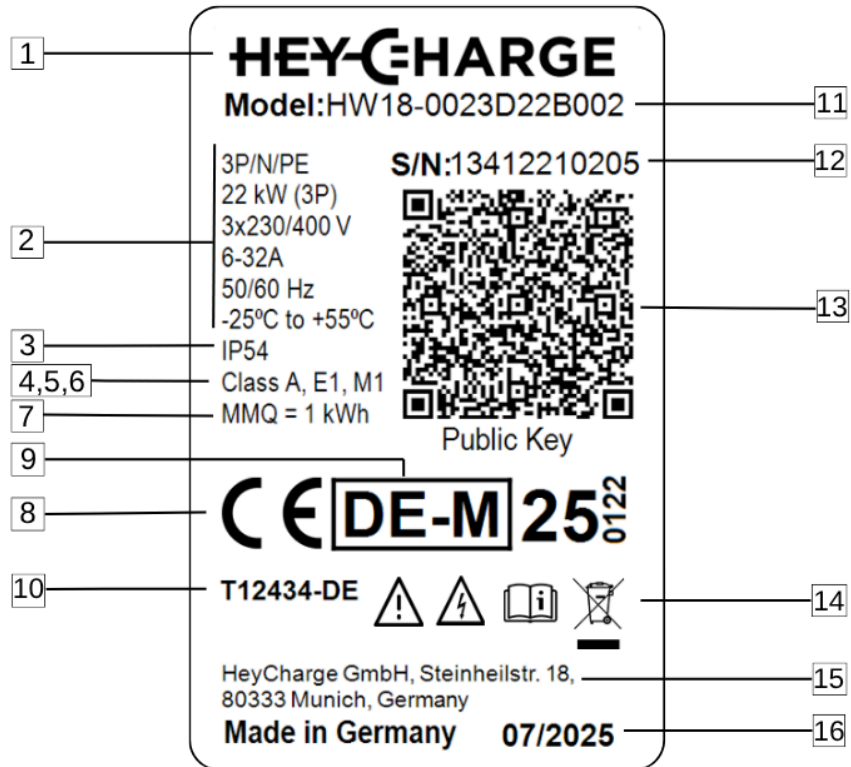

#	Meaning
1	Manufacturer's logo
2	Technical data
3	IP rating
4	Accuracy class
5	Electromagnetic environment's class
6	Mechanical environment's class
7	Minimum Measured Quantity
8	CE label

#	Meaning
9	Marking of the approval
10	Certification approval number
11	Model number
12	Serial number
13	Public Key
14	"Warning", "Danger", "Read manual", WEEE symbols
15	Manufacturer address
16	Production date

4. Datasheet

4.1. Features and specifications

- **SecureCharge** is a patent-pending replacement for a central server-based system requiring an internet connection at each site. Instead of an internet connection, the technology relay cryptographic tokens through HeyCharge mobile app to each charger, enabling a secure and bidirectional management channel for user access and billing data with zero latency.
- **HeyCharge mobile app** is available for iOS and Android platforms and allows users to start and stop charging sessions with no latency even in an environment with low or no internet connection.
- Trusted **power meter with OCMF** feature is the Class A, calibrated device which complies with German MessEV metrology regulations. This meter ensures all measurement data integrity and consistency across all data lifecycle. Measurement data signs by the meter and can not be manipulated by 3rd parties. You can find the screen of the meter at the left side of the device. For more information about the meter, visit the manufacturer's website:

<https://www.bzr-bauer.de/produkte/bsm-e-mobilitaet/> .



table: Device specifications

Model Number	HW18 Version	
Rated Input Voltage	230VAC \pm 10% / Single Phase	400VAC \pm 10% / Three Phase
Rated Input Current	32A	16/32A
AC Power Frequency	50/60 Hz	
Input Protection	UVP, OVP, OTP, RCD, SPD, Ground Fault Protection	
Output Protection	OCP, OTP, Control Pilot Fault Protection	
Output Interface	IEC62196-2 AC socket	
Storage Temperature	-40°C to +70°C	
Operation Temperature	-25°C to +55°C	
Relative Storage Humidity	< 95%	
Relative Operation Humidity	< 95%	
Connection Methods	Bluetooth, LAN	
Network Transmission Rate	10M / 100M	
Protection Level	IP54	
Installation Type	Wall-mounted	
Altitude	\leq 2000m	
Status Indication	RGB LED, LCD screen, Mobile app	

4.2. Device layout

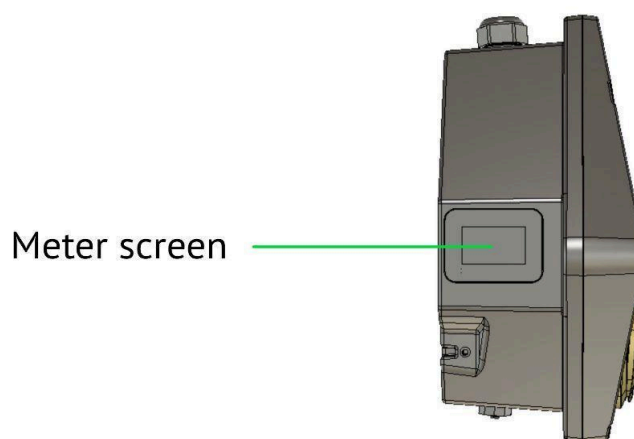
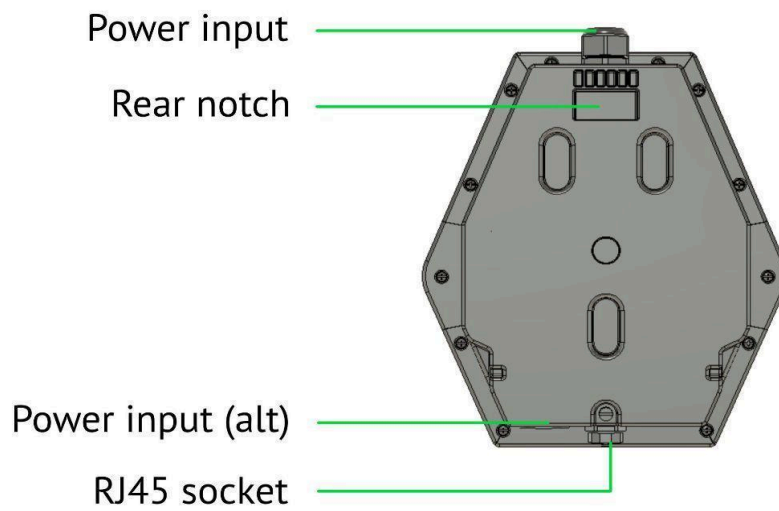
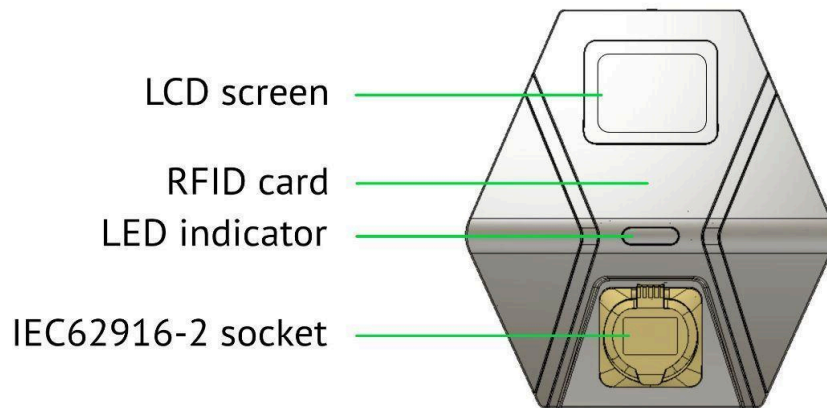

4.3. Device dimensions

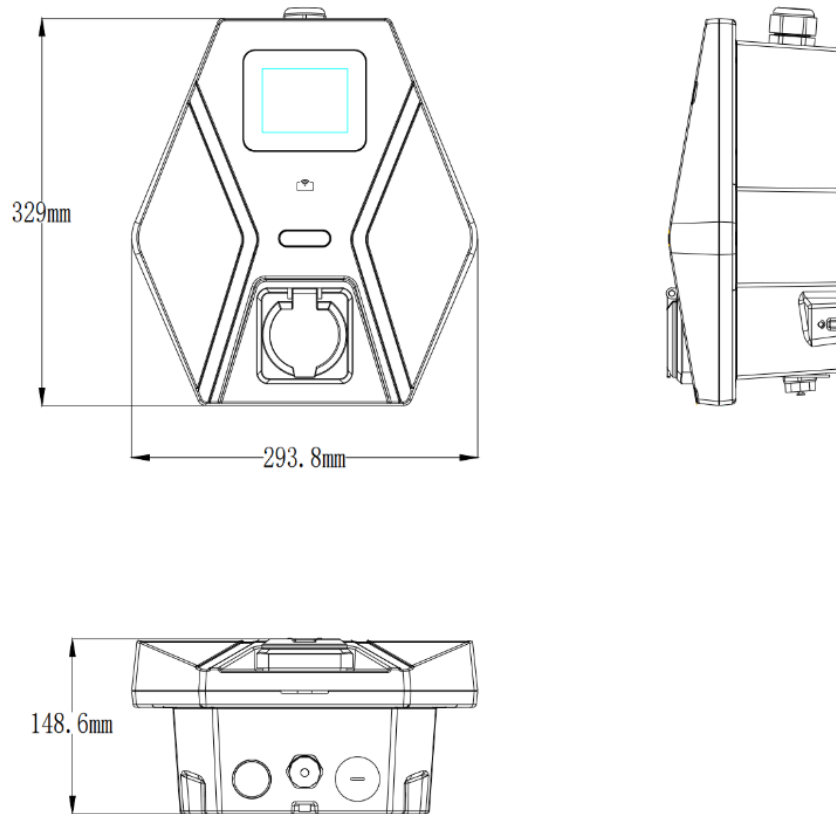

Wall-mounted bracket

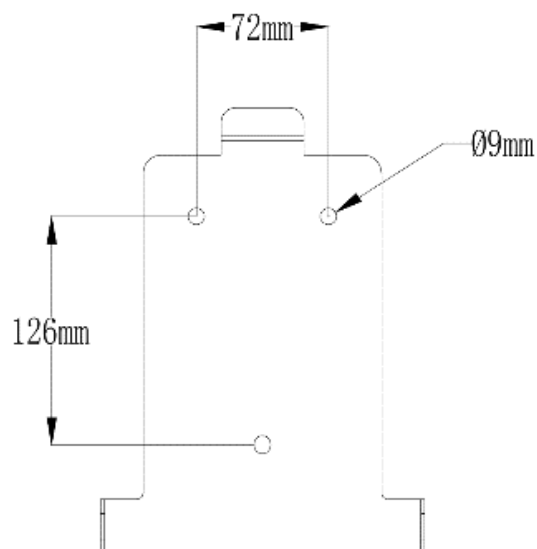

5. Installation Instructions

5.1. Safety requirements

- Be sure to preview the user manual and ensure local building and electrical codes are reviewed before installing the AC charger.
- The AC charger should be installed by a qualified technician according to the user manual and local safety regulations.
- Use appropriate protection when connecting to the main power distribution cable.
- Type B, C or D circuit breaker with the required rating (see table) should be installed in the upstream AC distribution box.
- The miniature circuit breaker for each non-earthed conductor of the AC input should be purchased by the customer.

5.2. Wiring



IMPORTANT NOTICE – AUTHORIZED INSTALLATION REQUIRED

Only **authorized installers** are permitted to modify or change the wiring inside the charger. Any wiring modifications must be **discussed and approved in advance with HeyCharge GmbH. Failure to comply with this requirement will result in the voiding of the product warranty.**

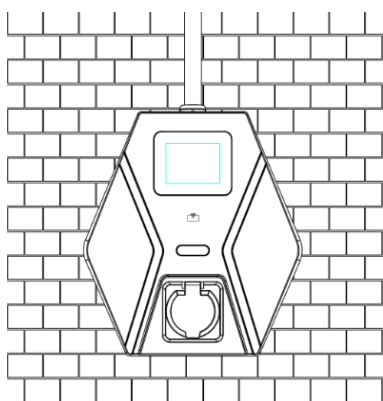

Input cable from a top

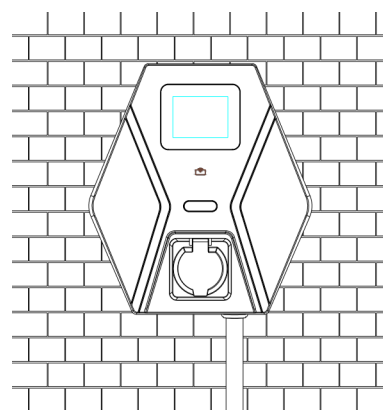

Input cable from a bottom

Single-phase connection

For safe use of electricity, please add circuit breaker protection in the input cable of the charging device. Connect the L lead of the input wire to the grid L, connect the N lead to the grid N. Connect the PE lead to the grid PE.

The input connection cable should comply with EN 50620:2017. It is recommended to use a 3-core/6mm cable (cross-linked polyethylene or equivalent) to pull out the single-phase cable from the distribution box.

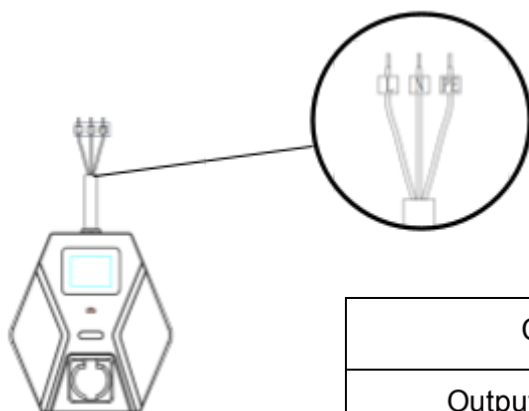

Circuit Breaker Options Table	
Output Amperage (A)	32A
Circuit Breaker Options (A)	40A

3-phase connection

For safe use of electricity, please add circuit breaker protection in the input cable of the charging device. Connect the L1 lead to the grid L1, connect the L2 lead to the grid L2, connect the L3 lead to the grid L3, connect the N lead to the grid N, and connect the PE lead to the grid PE.

The input connection cable should comply with EN 50620:2017. It is recommended to use a 5-core/6mm cable (cross-linked polyethylene or equivalent) to pull out the three-phase cable from the distribution box.

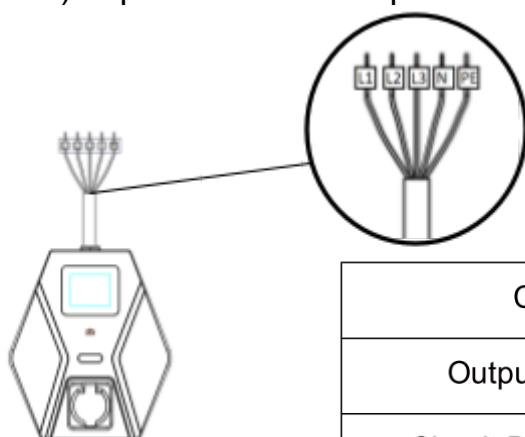

Circuit Breaker Options Table		
Output Amperage (A)	16A	32A
Circuit Breaker Options (A)	20A	40A

5.3. Tools required

Before installing the wall-mounted charger, ensure you have the following tools:

- Wire stripper
- Crimpers for terminals
- Phillips screwdriver
- Adjustable wrench
- Multimeter
- Leveling tool
- Drill

The device shall be mounted at a sufficient height from ground for at least 1.2m (4 ft). If several devices are mounted in a row it shall keep distance for at least 300mm (12 in) from each other.

5.4. Wall-mounted bracket installation

STEP 1

Drill 3 holes (for mounting screws) with a diameter of 8.5mm and a depth of 52mm by using our mounting template.

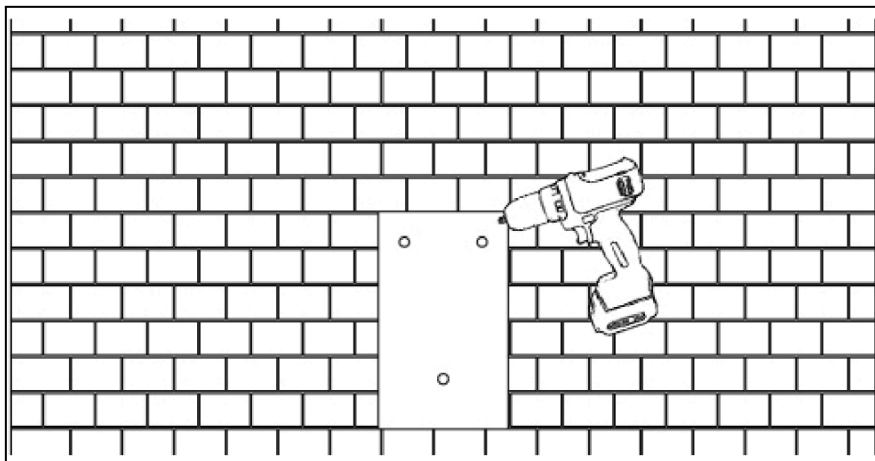

STEP 2

Use 3 sets of hex head screws to secure the wall-mounted bracket on the wall.

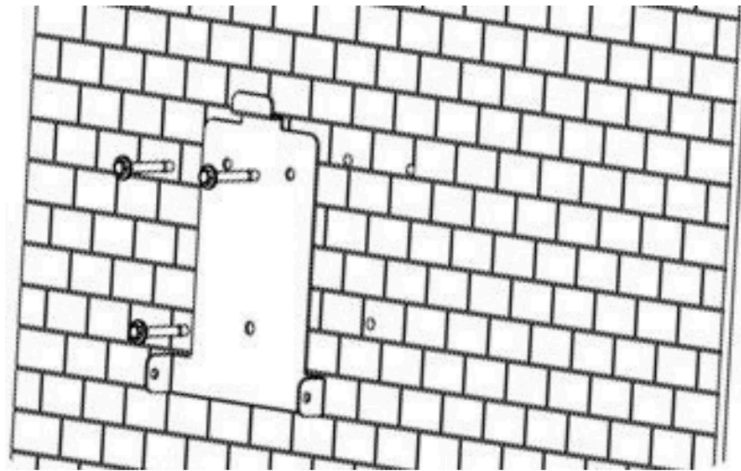

STEP 3

Align the rear notch of the charger with the wall-mounted bracket and fit the bracket's screw holes on the right and left side.

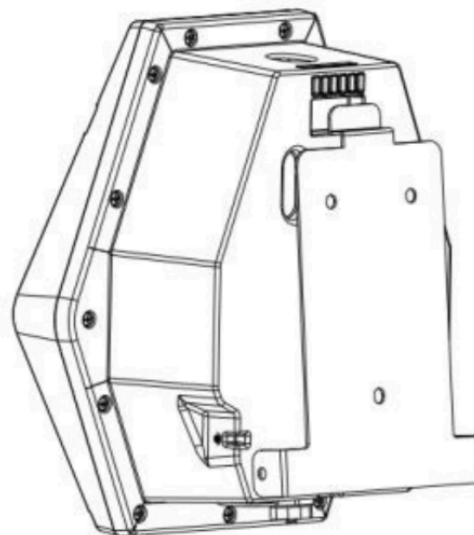

STEP 4

Tighten 2 sets of M5 screws from the right and left sides to complete the installation.

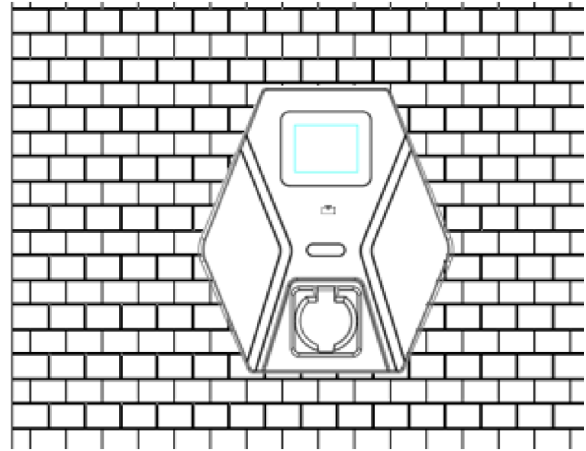
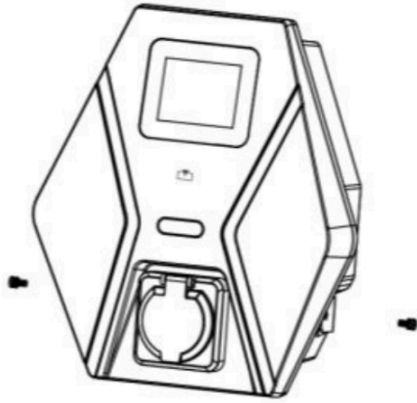

6. Device Interface

6.1. LED states description

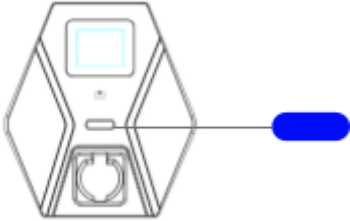
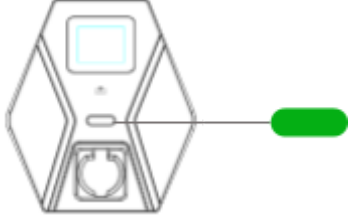
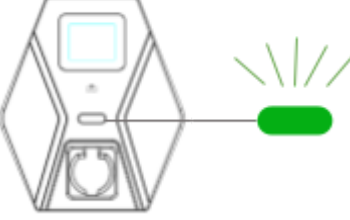
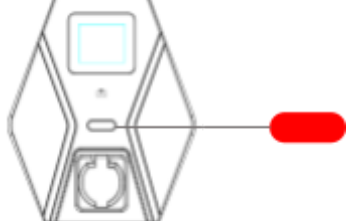
#	LED state	Description
1	SOLID BLUE 	Standby The blue light stays steady while the charger is ready and the cable is not connected to a vehicle.
2	SOLID GREEN 	Vehicle connected and ready to charge The green light stays steady while the charger is connected to a vehicle by a cable and ready to charge.
3	BLINKING GREEN 	Charging in progress The green light blinks while charging. The cable will be mechanically locked by the charger.
5	SOLID RED 	Error The red light indicates a faulting state. Please refer to "Error and Warning Messages" for detailed information.

6.2. Device screen description

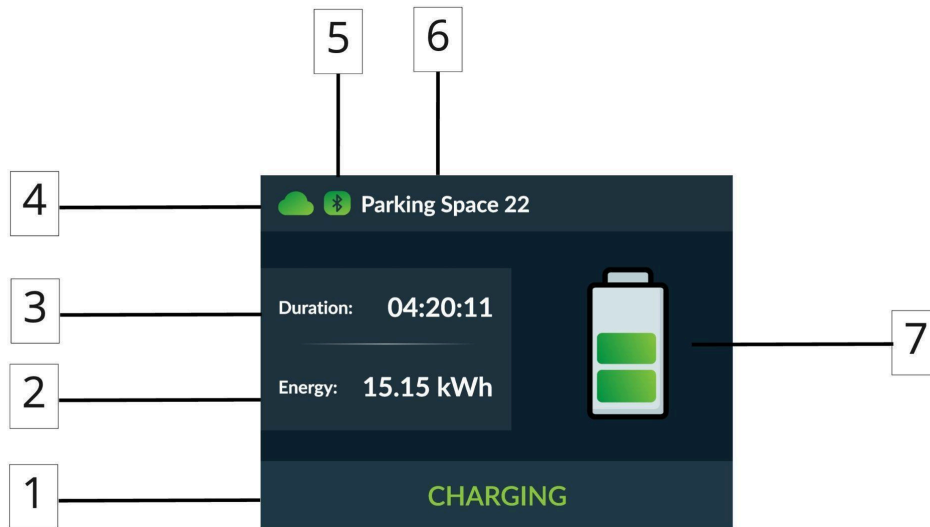

<u>Icon #</u>	<u>Meaning</u>
1	Current status
2	Energy consumption
3	Duration of the charging session
4	OCPP server status
5	Charger Bluetooth radio is active
6	Charger name
7	Current status icon

6.3. Power meter screen description

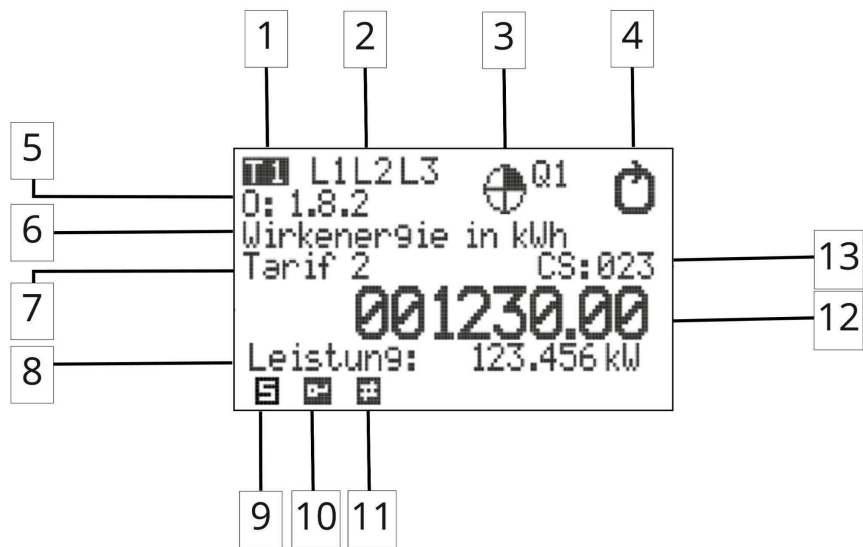

Icon #	Meaning
1	Shows the currently active tariff
2	Display for connected phases and phase sequence
3	Display of the quadrant
4	Display of energy direction
5	OBIS key figures
6	Display of the selected measuring unit
7	Display of the corresponding tariff
8	Display of the current power value
9	Symbol for service mode (visible only during production)
10	Symbol for verification mode (visible only during production)
11	Symbol for interface activity
12	Eight-digit display of the measured value
13	Checksum of the meter readings (only for digits before the decimal point)

7. Operating Instructions

Before you start, ensure you have:

- An IEC certified charging cable with at least 2 meters length and **Type 2** plug to fit the charging socket.
- The HeyCharge app installed on your phone: www.heycharge.com/go and the phone's bluetooth is on.



Type 2 plug



- All app actions described below need to be done **near the charger** to stay in your smartphone's bluetooth area.
- It can take up to **10 seconds** between tapping the button in the app and action taking effect on the charger hardware.

STEP 1

READY TO OPERATE: Make sure the charger is powered on and the LED indicator in the centre is constant blue.

Screen

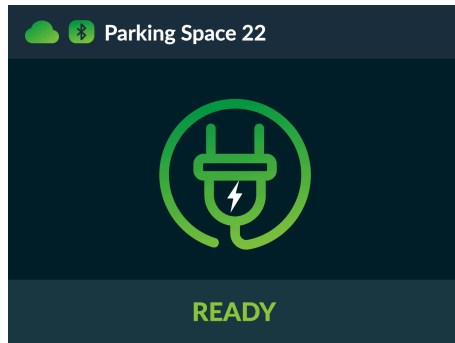

LED

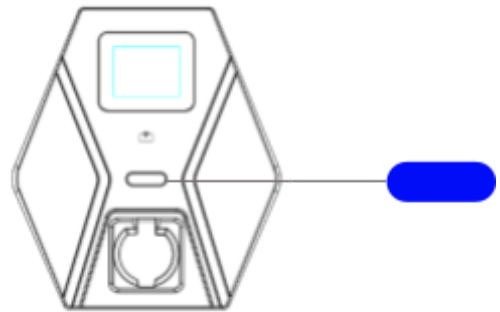

STEP 2

CONNECT YOUR VEHICLE: Connect your vehicle inlet and the charger outlet with the Type 2 charging cable.

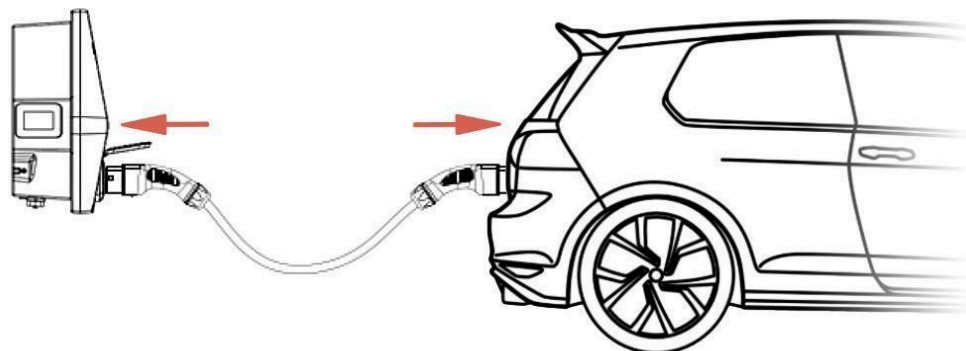

Charger LED will change its color to solid green after your vehicle is detected by the charger.

LCD screen

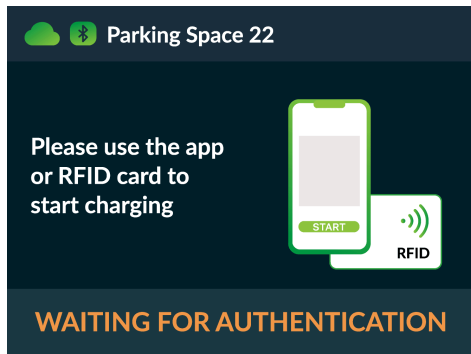

LED screen

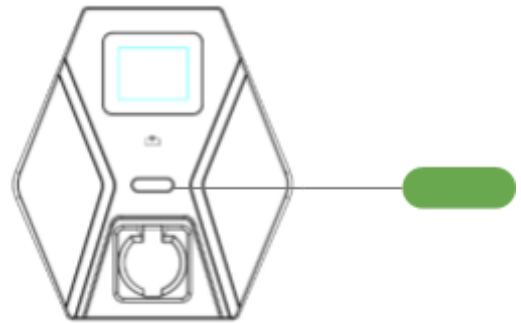

STEP 3

START CHARGING: Open Heycharge app and choose a charger from a list if there is more than one in range. You can recognize the exact charger by its serial number or property address.

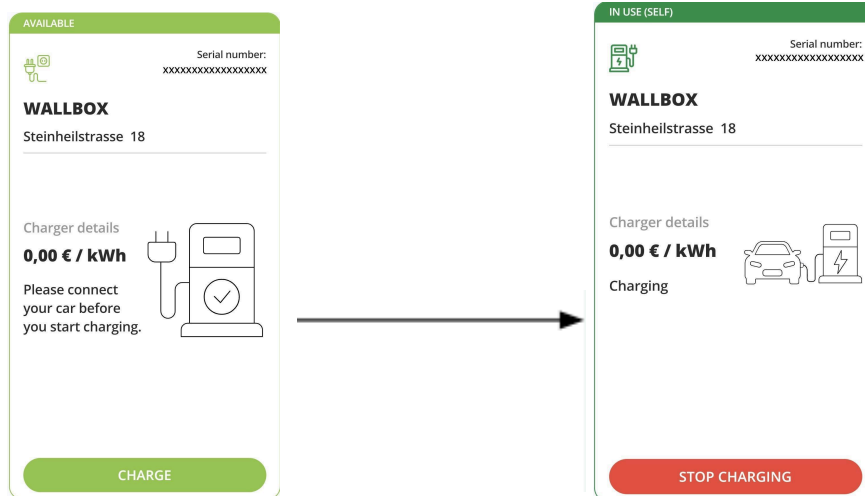

Tap the **CHARGE** button to begin charging. After the charging process has started the button will change to **STOP CHARGING** and the cable will be locked to the charger.

STEP 4

CHARGING: The LED indicator will become blinking green as soon as charging starts.

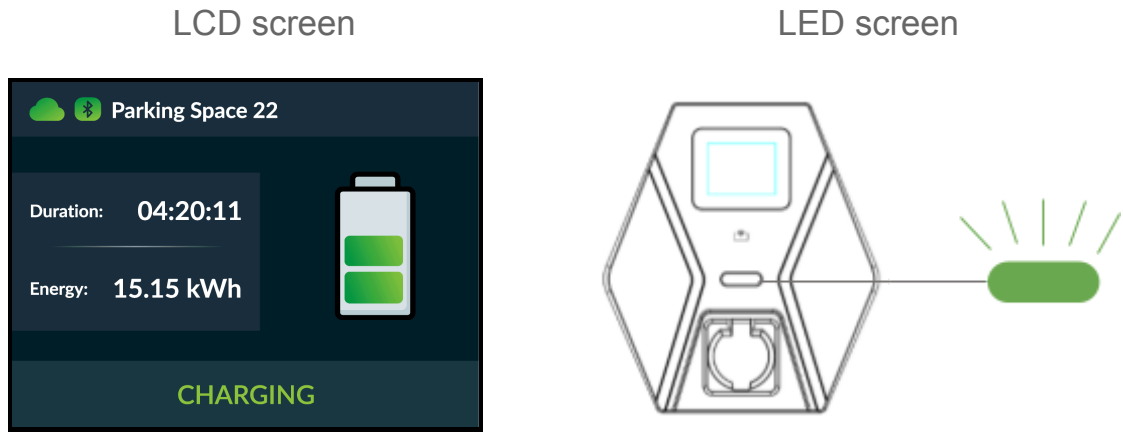

STEP 5

FINISH CHARGING: To finish charging choose the charger in the app and tap the **STOP CHARGING** button. After that charging process will stop, the LED indicator will stop blinking and become solid green, and the cable will be unlocked.

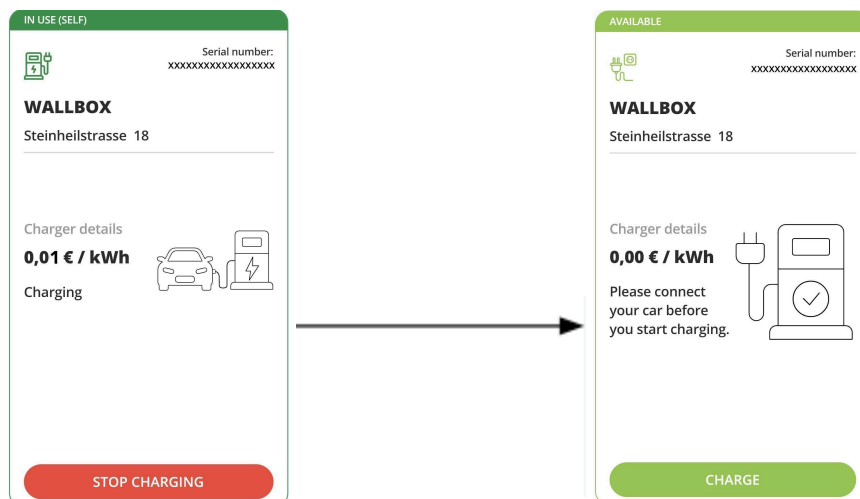

LCD screen

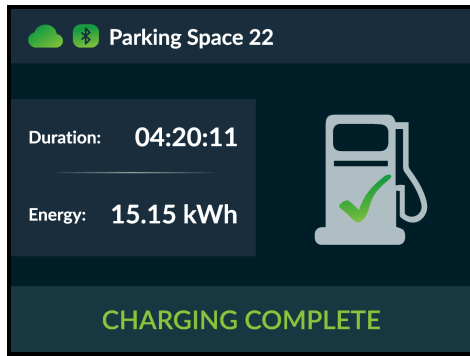

LED screen

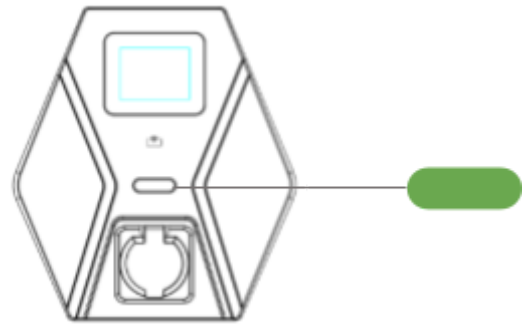

STEP 6

DISCONNECT YOUR VEHICLE: Remove the cable from the charger and vehicle. After that the LED indicator will changed from solid green to solid blue.

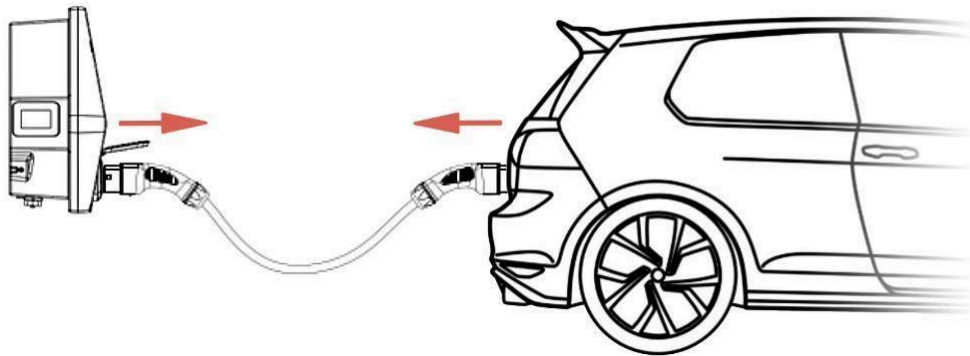

STEP 7 (optional)

GETTING CHARGING SESSION DETAILS: In the Heycharge app tap the **History** section at the bottom. Here you can find all of your charging sessions details and to download the OCMF (electronic receipt) for each. To do so: tap on the session, then to the “Download OCMF” button.

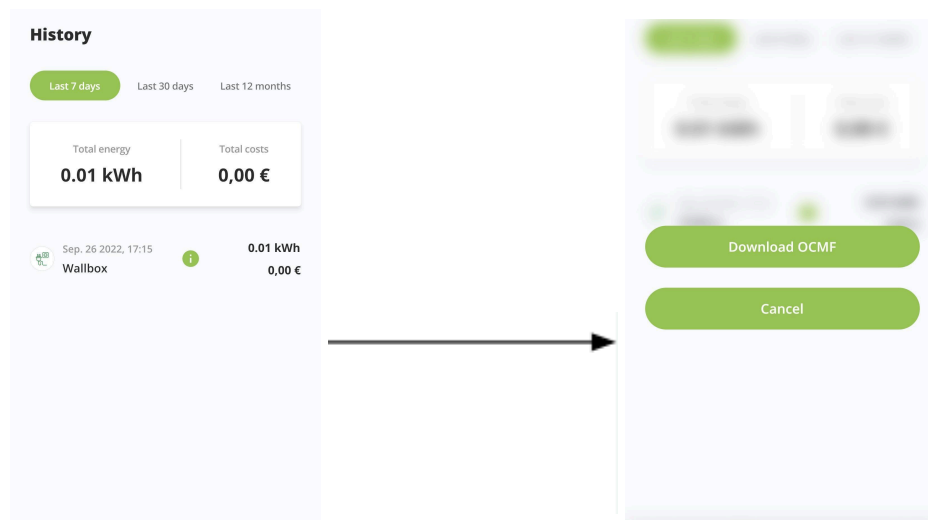

OCMF is a data standard for signed snapshot of exact charging session. It is provided as a part of German regulation for further use by the [S.A.F.E. transparency software](#).

8. List of possible errors and faults

If a charger error occurs, an error message is set on the screen of a charger and the LED indicator is red.

table: Errors and faults of the device

#	Error	Red LED state	Notes
1	Input OVP	1 quick blink, then 3 sec. pause	LCD screen showing “Charging Failure” warning. In most cases all of these errors could be recovered by cable unplugging.
2	Input UVP	2 blinks	
3	Output OCP	3 blinks	
4	OTP	4 blinks	
5	RCD abnormal	5 blinks	
6	Ground fault	6 blinks	
7	Control pilot fault	7 blinks	
8	MCU self-test fail	Solid red	These errors are critical. Unplug the cable and do not use the fault charger. Report charger to the Support Team by app, phone call or any other support channel.
9	RCD self-test fail		
10	Relay self-test fail		
11	RCD abnormal stop charging		
12	Output OCP stop charging		
13	OTP stop charging		

If a meter internal error occurs, an error message is set on the meter screen.

table: List of meter errors

<u>Error code</u>	<u>Description</u>
F.F(00000000)	No error set, meter is OK
F.F(xxxxxxx0)	Meter gauged (calibrated)
F.F(xxxxxxx1)	Meter is not gauged (calibrated)
F.F(xxxxxxx8)	Calibration release, the meter is calibrated, but can be re-calibrated
F.F(xxxxxxx9)	Calibration release, the meter is not yet calibrated and can now be calibrated
F.F(xxxxxxxF)	Meter initialized again, the default parameters are loaded
F.F(xxxxxx0x)	Meter in normal mode
F.F(xxxxxx1x)	Meter in service mode
F.F(xxxxx0xx)	Checksums Micro FLASH and EEPROM OK
F.F(xxxxx1xx)	Error Checksum Micro FLASH
F.F(xxxxx2xx)	Error Checksum EEPROM
F.F(xxxxx3xx)	Error Checksum Micro FLASH and EEPROM
F.F(xxxx0xxx)	Micro RAM and STACK OK
F.F(xxxx1xxx)	Error Checksum Micro RAM
F.F(xxxx2xxx)	Error Micro STACK (Overflow)
F.F(xxxx3xxx)	Error checksum micro RAM and error micro STACK
F.F(xxx0xxxx)	Micro OK
F.F(xxx1xxxx)	Error in micro
F.F(xx0xxxxx)	Hardware OK
F.F(xx1xxxxx)	Hardware error

F.F(x0xxxxxx)	Time base (Real Time Clock) OK
F.F(x1xxxxxx)	Time base error (Real Time Clock)
F.F(0xxxxxxx)	Real Time Clock set
F.F(1xxxxxxx)	Real Time Clock with default date/time (after repeated initialization)

9. Transparency software

A charging station is assessed for conformity with German calibration law (Eichrecht) according to MessEG/MessEV. It is treated as a complete measuring capsule. That means all data transactions are secured and each charging session data could be collected, and stored by the device. So users can export and validate their charging session data in the form of an OCMF record (see step 7 of Operational Instructions).

Validation can be done by 3rd-party open-source transparency software. Aside from OCMF record, which could be downloaded by HeyCharge app (see step 7 of Operational Instructions), users also need a Public Key of the exact charger. Public Key is not part of the OCMF record and could be found on the charger label in the form of QR-code (see Nameplate section of this manual).

We recommend to use following open-source transparency software to validate OCMF record by end user:

- **S.A.F.E.** — was developed by members of the association and is available to all association members as open source. You can find software and user manual on the website: <https://www.safe-ev.de/en/>
- **Chargy** — transparency software made by Eneco eMobility (former ChargeIT). You can find their cross-platform app here: <https://github.com/OpenChargingCloud/ChargyDesktopApp>



WARNING

10. Maintenance and warranty

There is a risk of injury for persons performing tasks for which they are neither qualified nor have received appropriate training.

- The maintenance / repair of the device may be performed only by persons who are familiar with this task, have been instructed with regard to the associated hazards and who possess the necessary qualifications.
- All technical safety conditions have to be satisfied prior to performing maintenance / repairs.

10.1. Environmental requirements

- Keep the charger clean and in a clean area with low humidity. Do not install it in an environment near the sea, with high oil concentration, high humidity or high dust.
- Avoid moisture or water inside the charger. If there is water or moisture ingress inside the enclosure, it is necessary to immediately power off to avoid electric shock hazard and notify the professional personnel to carry out maintenance before the next use.
- If there is any damage or dirt on the power socket, charging cable, or vehicle connector holder, please contact the maintenance personnel.
- Use the charger properly. Do not hit or press hard on the case. If the case is damaged, contact a maintenance team or professional technician.
- Avoid placing the charger near hot objects and at high-temperature locations and under direct sunlight. Keep it away from dangerous substances such as flammable gasses, chemicals and corrosive materials.
- Do not place external objects or heavy objects on top of the charger.

10.2. Maintenance plan

Carry out the following maintenance work at the specified intervals.

table: Maintenance every 4 months

<u>Part / Component</u>	<u>Maintenance work</u>
Enclosure	Visual inspection for defects or damage.
	Check the device for secure fastening.
	Clean the outside of the enclosure with damp cloth.
Front panel	Visual inspection for defects or damage.
Switching and safety devices	Visual inspection for defects or damage.
	Check the function of the circuit breaker.

table: Maintenance every 12 months

<u>Part / Component</u>	<u>Maintenance work</u>
Cable connections and connectors	Check for a firm fitting.
	Visual inspection for defects or damage.
Charging station	Visual inspection for defects or damage.
	Full Functional check.
System check	Check system health and fitness with the HeyCharge maintenance app.

10.3. Warranty

- The warranty period for the charger is 2 years.
- After the event of any repair or maintenance under the warranty period, if there is no purchase to extend the warranty service, HeyCharge GmbH shall provide a 3-months warranty period for any subsequent paid repair work.
- During the warranty period for any malfunction caused by normal use according to the Product Manual and Service Instruction (to be determined by certified maintenance technicians of HeyCharge GmbH), the product shall be repaired free of charge. Except for the following situations, the charger shall be subject to the above warranty terms:
 - A. The warranty certificate cannot be provided or the contents of the warranty certificate are modified or inconsistent with the label indication of the repaired product.
 - B. Customer are unable to provide valid proof of purchase.
 - C. Manufacturer's specified warranty period exceeds.
 - D. Device damaged due to not following the product service instruction for use, maintenance and storage.
 - E. Device damaged or malfunctioned due to an alien object.
 - F. Unauthorized repair, disassembly or modification.
 - G. Device damage caused by force majeure (such as lightning, excessive voltage, earthquake, fire, flood, etc.).
 - H. Malfunction and damage of the device caused by other unavoidable external factors. Malfunction and damage caused by improper use of equipment, such as water or other solutions entering inside the equipment.
 - I. Malfunction and damage of the device caused by the grid power supply and voltage which is not specified for use with such equipment.
- The above guarantees shall be made solely, and no other express or implied warranties shall be made (including the implied warranties of merchantability, particular and applicable reasonableness and adaptability, etc.), whether in the contract or civil negligence.

11. Declarations of Conformity

This product complies with the applicable requirements of EU and national legislation. The following declarations are included:

11.1. CE Declaration of Conformity

This declaration confirms compliance with the essential requirements of the following EU directives:

2014/30/EU (EMC)

2014/35/EU (LVD)

2014/53/EU (RED)

The CE Declaration of Conformity is available upon request. To request a copy, please contact: kundenservice.de@heycharge.com or your reseller.

11.2. MessEV Declaration of Conformity

This product complies with the German Measurement and Verification Act (MessEG) and associated regulations. The conformity assessment is based on the following:

- REA document 6-A: “Rules and findings of the rule determination committee according to § 46 MessEG for measuring and additional devices in the field of e-mobility”, dated 16 March 2017
- PTB-A 50.7: “Requirements for electronic and software-controlled measuring devices and additional devices for electricity, gas, water and heat”, dated April 2002

Conformity Modules and Certificates:

1. Module B – Certificate No.: T12434-DE, issued 04.04.2023
2. Module D – Certificate No.: DE-015, issued 27.07.2023

The full Eichrecht Declaration of Conformity is available at:

 <https://www.heycharge.com/resources>

12. Legal Obligations under MessEG / MessEV

As the Charge Point Operator (CPO) under the German Measurement and Verification Act (MessEG), our company ensures that the charging infrastructure is operated in compliance with the applicable calibration law and relevant technical requirements.

12.1. Obligations as CPO (Charge Point Operator)

1. The charging equipment is installed and operated under environmental conditions defined in the type examination certificate.
2. The reverification period of the charging device and its components is tracked and respected.
3. Signed measurement data packets are stored:
 - a. Permanently and in chronological order with pagination
 - b. On dedicated local memory
 - c. Retained beyond the transaction period, in accordance with legal appeal periods
 - d. Made available to authorized third parties upon request
 - e. No substitute values are used for billing
4. An electronic version of this manual, including this section, is made available to end users who receive measured values.
5. Upon request, complete memory contents for billing periods are made available to authorities.

12.2. Responsibilities of the EMSP (User of Measured Values)

Note: HeyCharge GmbH does not act as an EMSP. The following obligations apply to the party that uses the legally measured values in commercial transactions.

1. Only legally valid signed measured values may be used for billing purposes.

2. Signed data packets must be securely stored without modification, traceable, and available for verification.
3. No substitute or estimated values may be used for billing if the original signed values are missing.
4. The EMSP must retain the data for at least the statutory retention period applicable to the business transaction.
5. Upon request, the EMSP must provide the measured values transparently to the billed customer.

By fulfilling the responsibilities defined under REA document 6-A and PTB-A 50.7, our company guarantees the legally compliant use of this charging equipment in accordance with German metrology regulations.